

Sport Exhaust System (I-no. XLF/XLX)

Concern: **Retrofitting**

Model Year: **As of 2017**

Engine Types: MA220 = 2.0 l
MA222 = 2.5 l

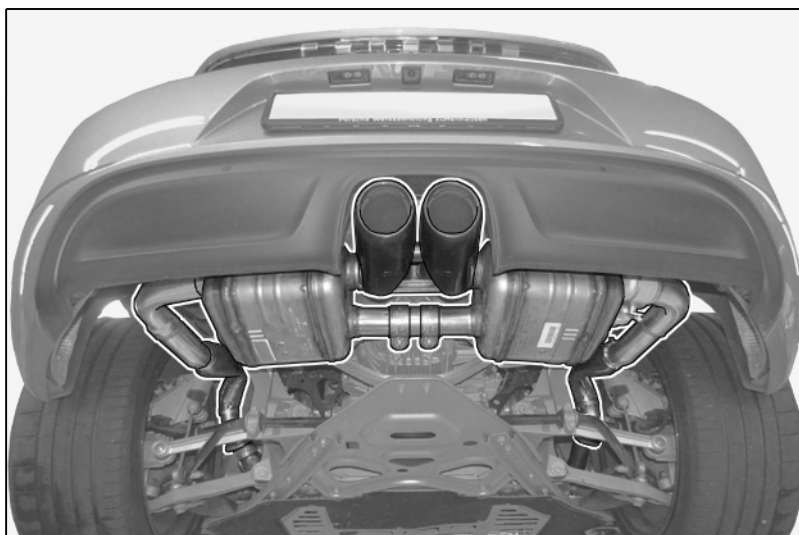

Notes: The sport exhaust system can be activated/deactivated by pressing the button with the "Twin tailpipe" symbol. The sport exhaust system is also active in "Sport" or "SportPlus" mode. Here, the sports exhaust system can be switched off or even switched on again using the "Twin tailpipe" button.

The switch console (combined switch) is a repair kit and must also be ordered. The repair kit contains the main body, the required buttons and the trims. The new switch console is assembled in accordance with the new vehicle equipment.

Engine power and exhaust behaviour of the vehicle are not affected. The sports exhaust system is also available ex-works for new vehicles by requesting optional equipment **XLF** or **XLX**.

Parts Info: **982.044.200.00** ⇒ Sport exhaust system with sports tailpipe, silver, set
982.044.200.01 ⇒ Sport exhaust system with sports tailpipe, black, set
982.044.200.02 ⇒ Sport exhaust system without sports tailpipe, set

Also order the following:

991.613.955.50 DML

Combined switch (switch console)

Parts list:

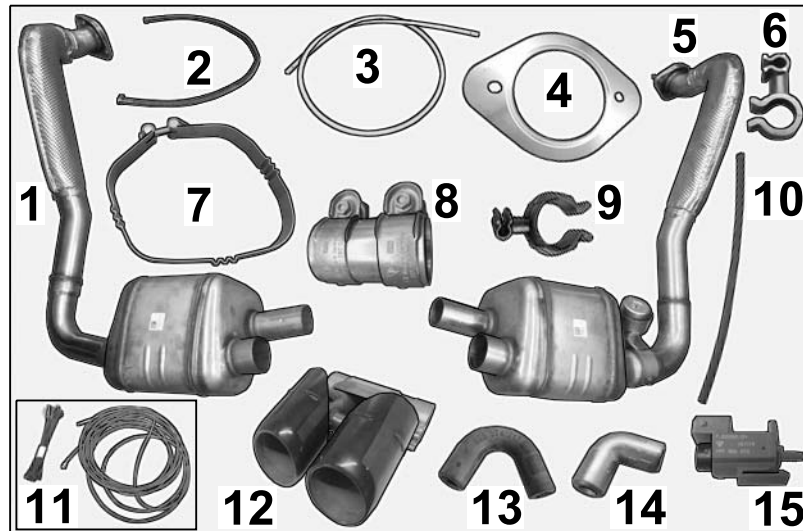

Figure 2

982.251.051.C	1 x	Rear muffler, left ⇒ Figure 2-1-
991.111.495.00	1 x	Vacuum line (steel flexi-pipe), 640 mm ⇒ Figure 2-2-
900.918.033.40	1 x	Plastic tube, 5 x 1 x 1, 100 mm ⇒ Figure 2-3-
982.251.263	2 x	Flange seal ⇒ Figure 2-4-
982.251.052.C	1 x	Rear muffler, right ⇒ Figure 2-5-
999.507.821.40	2 x	Combination holder, 4.3 - 11 ⇒ Figure 2-6-
982.251.571.E	2 x	Clamp ⇒ Figure 2-7-
981.111.280.00	1 x	Clamping sleeve ⇒ Figure 2-8-
999.591.820.40	1 x	Combination holder, 4.3 - 25 ⇒ Figure 2-9-
999.181.473.40	1 x	Protective tube ⇒ Figure 2-10-
981.612.905.00	1 x	Line (BK/YE) with tie-wrap ⇒ Figure 2-11-
982.251.187.J ¹	1 x	Sports tailpipe, black ⇒ Figure 2-12-
928.574.717.07	2 x	Molded hose, bent ⇒ Figure 2-13-
9A1.110.666.00	1 x	Angled pipe ⇒ Figure 2-14-
7PP.906.270	1 x	Change-over valve ⇒ Figure 2-15-
982.251.187.L ²	1 x	Sports tailpipe, silver
999.651.360.01	1 x	Cable attachment, 6.00 (not shown)
811.971.848.B	1 x	Cable attachment (not shown)
3D0.971.939.B	2 x	Clamp, 6.00-9.00 (fixing clip on transmission, not shown)
900.910.003.03	4 x	Hexagon nut, M8 (not shown)
999.650.566.22	1 x	Socket contact (not shown)

9A7.007.483.00	4 x	Torx screw, M10 x 28 (for securing seat, not shown)
900.918.005.40	1 x	Plastic tube, 5 x 1 x 1,000 mm (not shown)

1 Only contained in set 982.044.200.01.

2 Only contained in set 982.044.200.00.

Materials:	000.043.004.82	1 x	Optimol-HT mounting paste
	— — —		Rust solvent, commercially available, e.g. WD40

Notes: **Identifying features when installed:**
A part number and the Porsche logo are shown on the rear muffler and tailpipe.

Tools: **9900 - PIWIS Tester 3**
P300 - Socket-wrench insert
9259 - Socket-wrench insert

Work Procedure: 1 Preparatory work:

- 1.1 Remove passenger compartment interior.
 - 1.1.1 Remove inner door sill trim on the left. ⇒ *Workshop Manual '680519 Removing and installing inner door sill trim'*
 - 1.1.2 Remove left front seat. ⇒ *Workshop Manual '720119 Removing and installing front seat'*
 - 1.1.3 Loosen belt fitting in the left B-pillar sill area. ⇒ *Workshop Manual '691119 Removing and installing front three-point belt'*
 - 1.1.4 Remove belt strap guide at the right and side trim panel at the left. ⇒ *Workshop Manual '707519 Removing and installing side trim panel'*

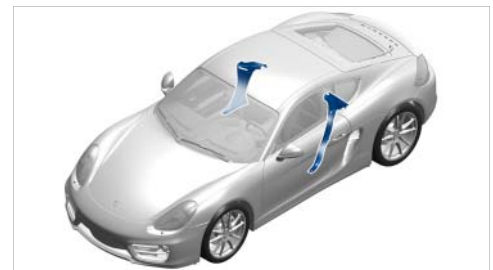

Figure 3

1.1.5 Remove trim panel for rear wall.
⇒ *Workshop Manual '703119
Removing and installing trim panel
for rear wall'*

1.1.6 Remove rear wall cover. ⇒
*Workshop Manual '555919
Removing and installing rear wall
cover'*

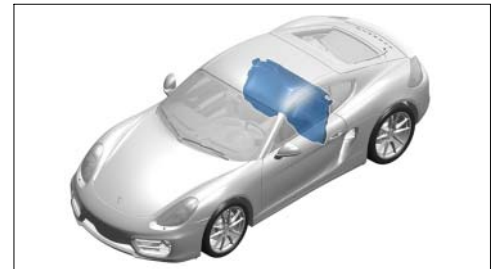

Figure 4

1.2 Remove luggage compartment interior.

1.2.1 Remove trim panel for package box
(lid) ⇒ *Figure 5-4-.* ⇒ *Workshop
Manual '706619 Removing and
installing package box'*

1.2.2 Remove side trim panels for
luggage compartment at the left ⇒
Figure 5-1- and right. ⇒ *Workshop
Manual '700319 Removing and
installing side trim panel for rear
luggage compartment'*

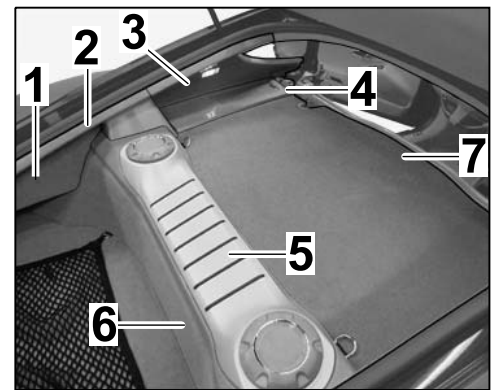

Figure 5

1.2.3 Remove C-pillar trim panels
(rear section) at the left ⇒ *Figure 5-2-* and right. ⇒ *Workshop Manual '706819
Removing and installing C-pillar trim panel'*

1.2.4 Remove C-pillar trim panel (front section) at the left ⇒ *Figure 5-3-.* ⇒ *Workshop
Manual '706819 Removing and installing C-pillar trim panel'*

1.2.5 Remove rear cover ⇒ *Figure 5-5-.* ⇒ *Workshop Manual '705319 Removing and
installing rear cover'*

1.2.6 Remove trim panel for rear luggage compartment (front section) ⇒ *Figure 5-6-.*
⇒ *Workshop Manual '700619 Removing and installing trim panel for rear luggage
compartment (front section)'*

1.2.7 Remove trim panel for convertible top compartment/engine compartment lid ⇒
Figure 5-7-. ⇒ *Workshop Manual '700819 Removing and installing trim panel for
convertible top compartment/engine compartment lid'*

1.2.8 Remove package box. ⇒ *Workshop Manual '706619 Removing and installing
package box'*

- 1.2.9 Remove storage box ⇒ *Figure 6-1-* and sound absorber ⇒ *Figure 6-2-*.
- 1.3 Remove engine compartment lid. ⇒ *Workshop Manual '557819 Removing and installing engine compartment lid'*
- 1.4 Remove rear wheels. ⇒ *Workshop Manual '440519 Removing and installing wheel'*
- 1.5 Remove exhaust system. ⇒ *Workshop Manual '260119 Removing and installing exhaust system'*

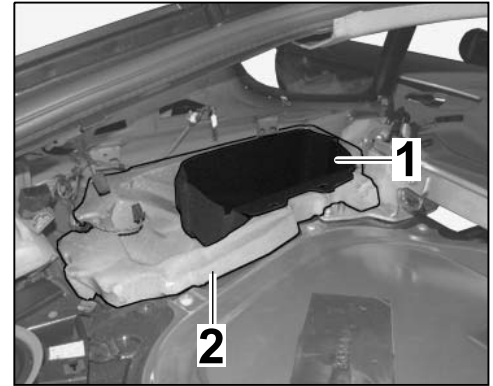

Figure 6

- 2 Route and connect line (BK/YE).
- 2.1 Installation position of connection point
 - 1 – Connection point X3_1
 - 2 – DME control unit
- 2.2 Loosen DME control unit and set it aside. ⇒ *Workshop Manual '247019 Removing and installing digital engine electronics control unit'*
- 2.3 Connect line (BK/YE) to the black 17-pin connector socket (connection point X3_1).

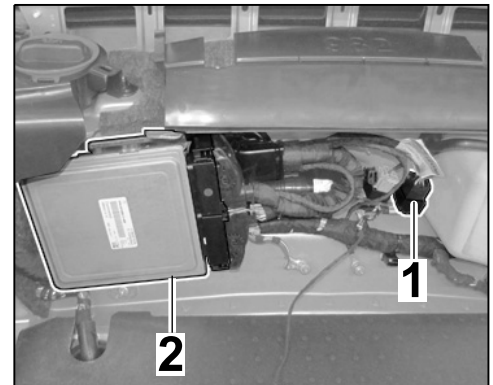

Figure 7

- 2.3.1 Disconnect electric plug connection. To do this, open the locking mechanism ⇒ *Figure 8-a-* and pull out the plug socket ⇒ *Figure 8-b-*.

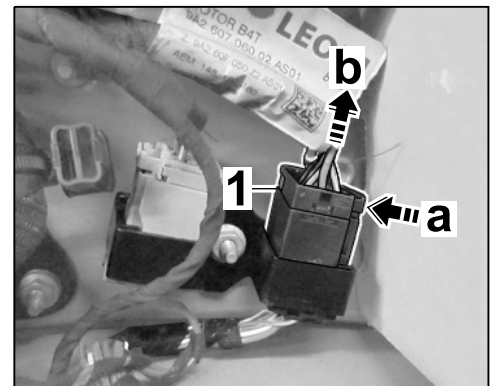

Figure 8

- 2.3.2 Release pin connector socket ⇒ *Figure 9-1-* (⇒ *Figure 9-a-*) and pull it down out of the holder ⇒ *Figure 9-2-*.

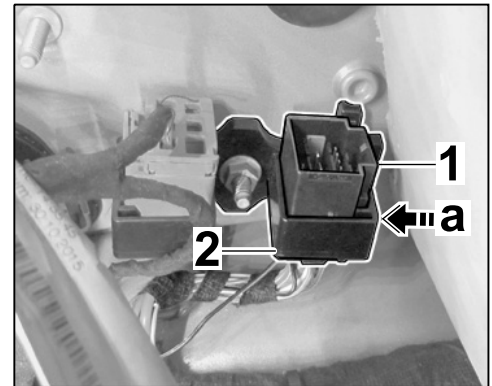

Figure 9

- 2.3.3 Release secondary lock on pin connector socket ⇒ *Figure 10-1-* (⇒ *Figure 10-a-*).

**Information**

Ensure socket contact is seated securely.

Insert pin contact of line (BK/YE) into chamber 2 ⇒ *Figure 10-b-*.

Close secondary lock.

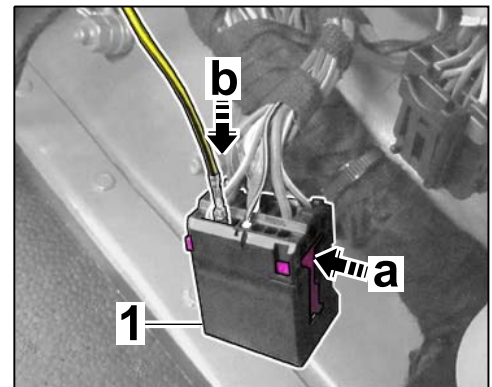

Figure 10

- 2.3.4 Fit pin connector socket ⇒ *Figure 11-1-* into the holder ⇒ *Figure 11-2-* (⇒ *Figure 11-a-*).

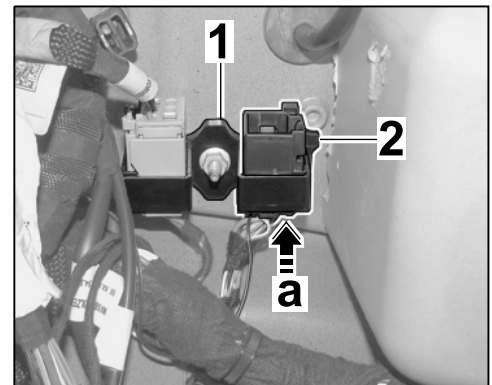

Figure 11

- 2.3.5 Connect electric plug connection ⇒ *Figure 12 -1-* (⇒ *Figure 12 -b-*).
- 2.4 Route line (BK/YE) as follows and secure with a tie-wrap to existing lines or components without tension and so that no chafing occurs: Connection point X3_1 → convertible-top compartment at the left → cable duct → along standard main wire harness for passenger compartment at the left → rear-end electronics control unit

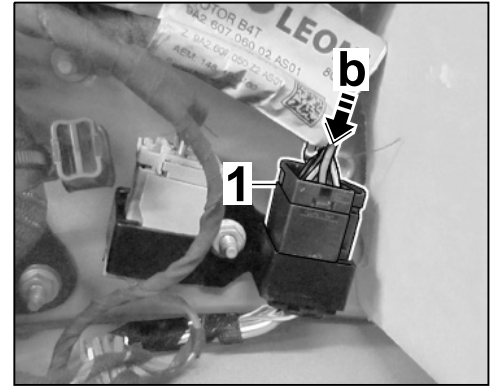

Figure 12

- 2.4.1 Route line (BK/YE) ⇒ *Figure 13 -1-* along the standard main wire harness for luggage compartment at the left.

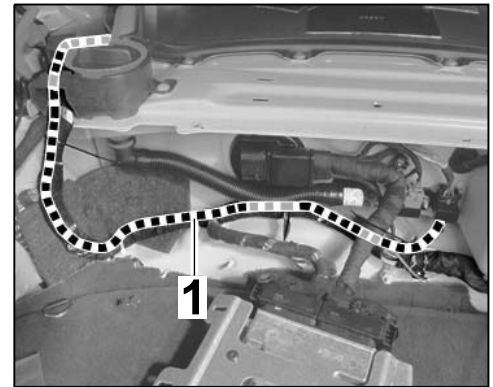

Figure 13

- 2.4.2 Route line (BK/YE) ⇒ *Figure 14 -1-* along the standard main wire harness for convertible-top compartment at the left.
- 2.4.3 Fold up carpet at the front left.

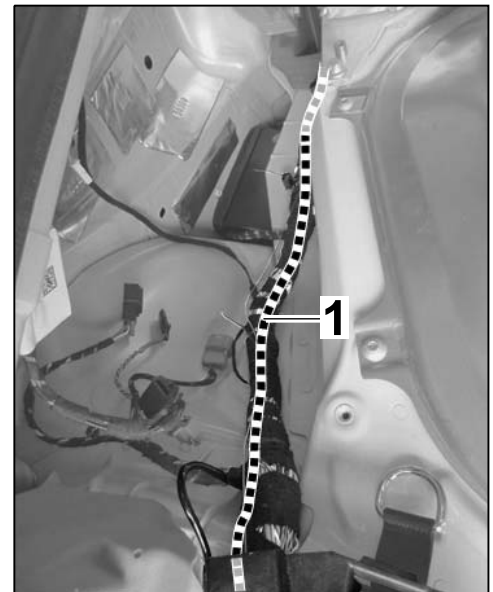

Figure 14

- 2.4.4 Route line (BK/YE) ⇒ *Figure 15-1-* through the cable duct ⇒ *Figure 15-3-* along main wire harness for passenger compartment at the left to the rear-end electronics control unit ⇒ *Figure 15-2-*. Open the cable duct if necessary.
- 2.4.5 Fold back carpet at the front left.
- 2.5 Connect line (BK/YE) to the rear-end electronics control unit.
- 2.5.1 Shorten line (BK/YE) and crimp together using a new socket contact (999.650.566.22).
- 2.5.2 Fold up the carpet ⇒ *Figure 16-1-* (⇒ *Figure 16-a-*).
Remove rear-end electronics control unit ⇒ *Figure 16-2-* from the foam holder ⇒ *Figure 16-3-*.

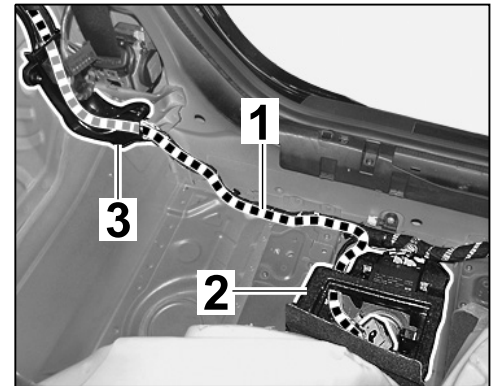

Figure 15

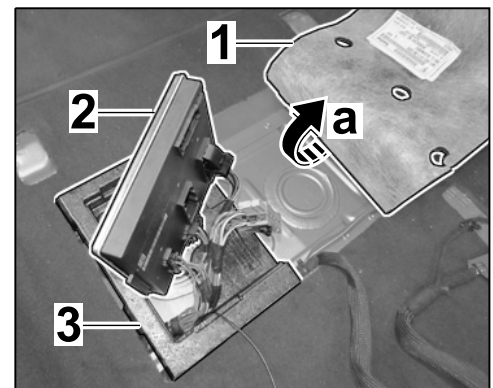

Figure 16

- 2.5.3 Disconnect electric plug connection ⇒ *Figure 17-2-* (blue) by pressing the locking mechanism and swivel the clip ⇒ *Figure 17-1-* upwards.

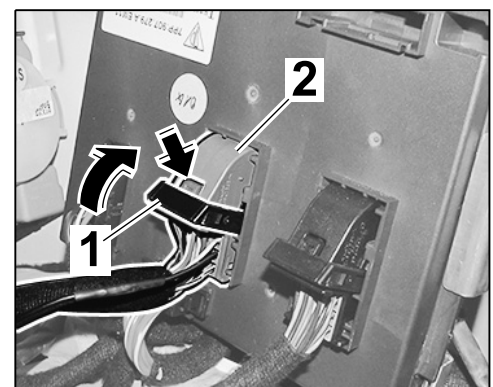

Figure 17

- 2.5.4 Press down the locking mechanism ⇒ *Figure 18 -arrow-* and push the grey plug socket ⇒ *Figure 18-1-* out of the plug carrier ⇒ *Figure 18 -2-*.

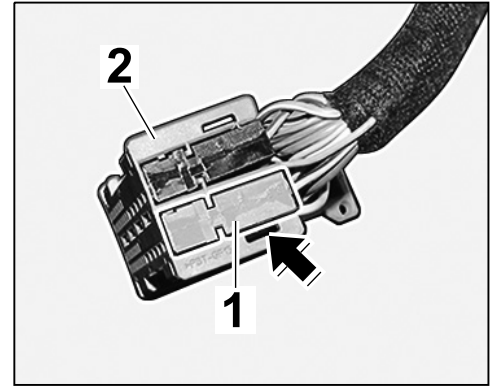

Figure 18



Information

Ensure socket contact is seated securely.

- 2.5.5 Insert socket contact ⇒ *Figure 19 -1-* into chamber A2 of the grey plug socket ⇒ *Figure 19-2-*.

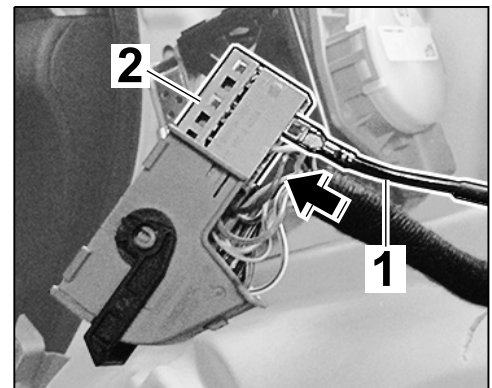

Figure 19

- 2.5.6 Push grey plug socket ⇒ *Figure 20 -1-* into the plug carrier ⇒ *Figure 20-2-* until the locking mechanism ⇒ *Figure 20-arrow-* engages.

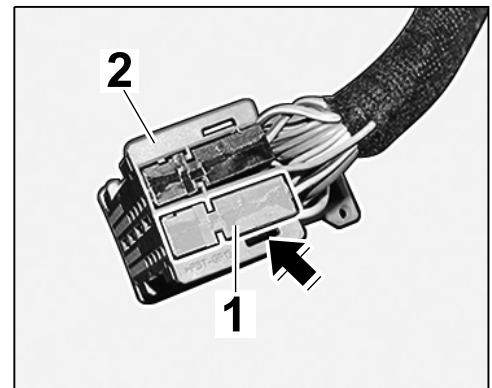

Figure 20

- 2.5.7 Connect electric plug connection ⇒ *Figure 21-2*- and swivel the clip ⇒ *Figure 21-1*- downwards.
- 2.5.8 Insert rear-end electronics control unit into the foam holder.
- 2.5.9 Fold back the carpet.
- 2.6 Secure DME control unit. ⇒ *Workshop Manual '247019 Removing and installing digital engine electronics control unit'*
- 3 Install vacuum lines.

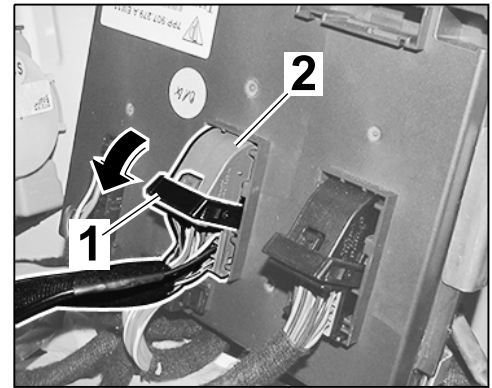

Figure 21

- 3.1 Overview of vacuum lines
- 1 – T-piece (standard)
 - 2 – Plastic tube, 100 mm
 - 3 – Angled pipe
 - 4 – Moulded hose, bent (928.574.717.05)
 - 5 – Change-over valve
 - 6 – Connector for change-over valve
 - 7 – Plastic tube, 1,010 mm with protective tube
 - 8 – Cable attachment (811.971.848.B)

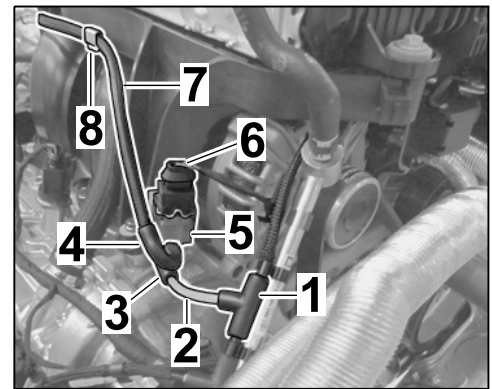

Figure 22

- 3.2 Cut a 1,010-mm length from the supplied plastic pipe (900.918.033.40).

**Information**

Insert vacuum line at least 10 mm into the steel flexi-pipe.

- 3.3 Connect vacuum line (from change-over valve to control box) ⇒ *Figure 23* and lock single-lug clip.

- 1 – Vacuum line (steel flexi-pipe), 640 mm
- 2 – Single-lug clip
- 3 – Plastic tube, 1,010 mm
- 4 – Protective tube
- 5 – Molded hose, bent (928.574.717.05)

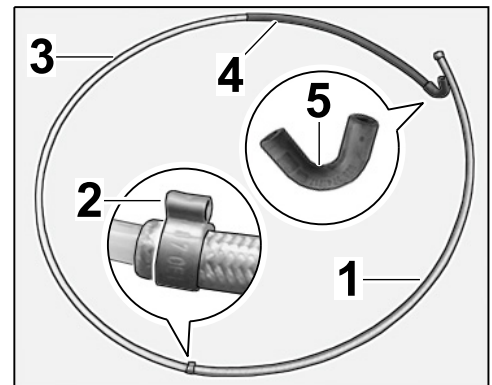

Figure 23

- 3.4 Cut a 100-mm length from the supplied plastic pipe (900.918.005.40).



Information

Insert vacuum line at least 10 mm into the steel flexi-pipe.

- 3.5 Connect 100-mm plastic tube ⇒ *Figure 24 -1-* and angled pipe ⇒ *Figure 24 -2-* together.
- 3.6 Install change-over valve.

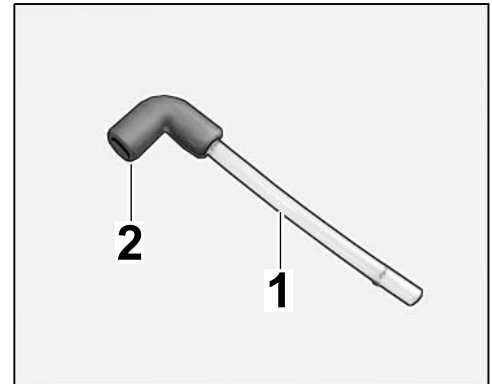

Figure 24



Information

The connector for the wire harness for the change-over valve is secured to the charge-air cooler holder.

- 3.6.1 Expose wire harness for change-over valve.
 - 1 – Connector on wire harness for change-over valve
 - 2 – Pulley for generator
 - 3 – Charge-air cooler holder

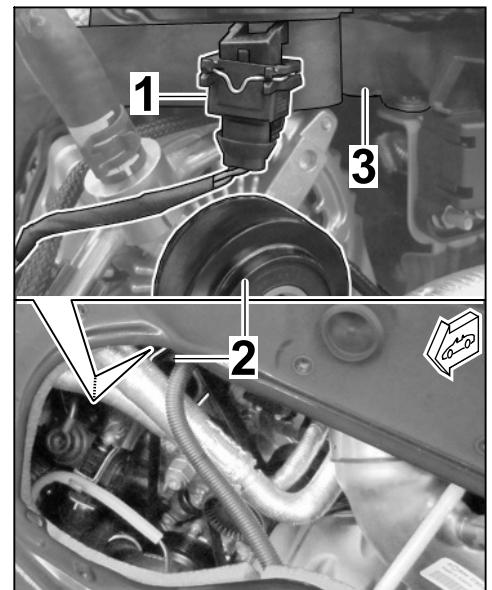

Figure 25

- 3.6.2 Pull dummy plug ⇒ *Figure 26-2-*
out of the T-piece ⇒ *Figure 26-1-*
(⇒ *Figure 26-a-*).

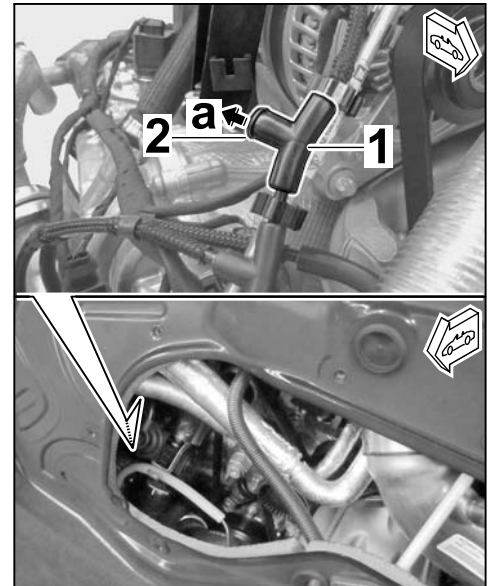

Figure 26

- 3.6.3 Insert 100-mm plastic tube ⇒
Figure 27-1- into the T-piece ⇒
Figure 27-2- (⇒ *Figure 27-a-*).

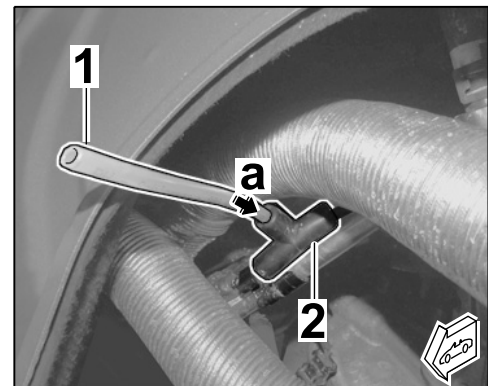

Figure 27

- 3.6.4 Push change-over valve ⇒ *Figure 28-1-*
into the holder ⇒ *Figure 28-4-*
(⇒ *Figure 28-b-*).

Fit angled pipe ⇒ *Figure 28-2-* on
change-over valve ⇒ *Figure 28-a-*.

Connect electric plug connection ⇒
Figure 28-3-.

- 3.7 Route vacuum line (from change-over valve to
control box).

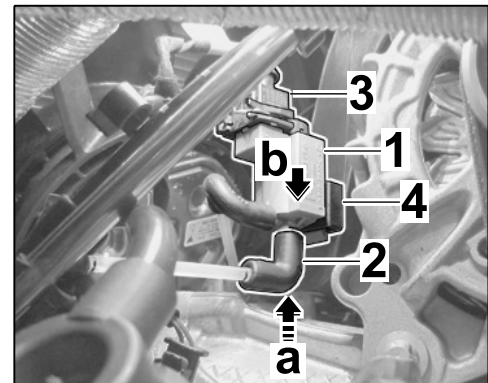

Figure 28

- 3.7.1 Loosen screw-type clamps ⇒ *Figure 29-2*- and remove moulded hose ⇒ *Figure 29-1*- for the throttle housing.

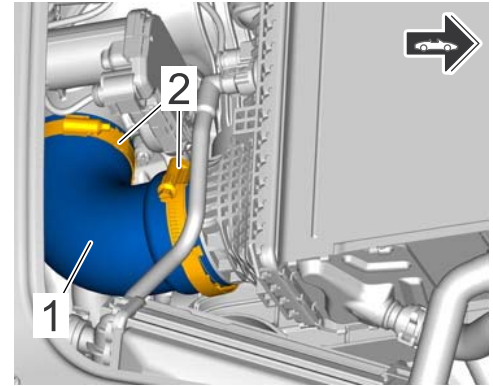

Figure 29



Information

Because the view of the components is obstructed in the installation area, they are shown with the engine removed.

- 3.7.2 Overview: Vacuum line routing from change-over valve to control box (using PDK as an example).

- 1 – Moulded hose, bent (928.574.717.05)
- 2 – Protective tube
- 3 – Cable attachment (811.971.848.B)
- 4 – Vacuum line
- 5 – Combination holder, 4.3-11
- 6 – Combination holder, 4.3-25
- 7 – Clamp, 6.00-9.00 (3D0.971.939.B)

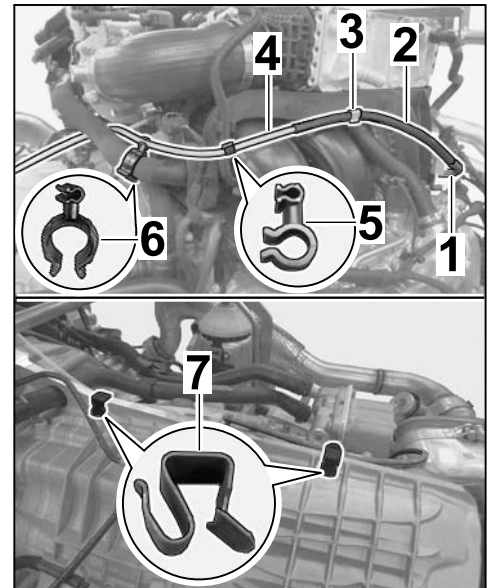

Figure 30

- 3.7.3 Route vacuum line ⇒ *Figure 31*
-1- at the side along the charge-air cooler holder to the change-over valve. Fit bent molded hose ⇒ *Figure 31-2-* on side connection.

- A** – View of engine compartment, top
B – View with engine removed
C – View through rear wall opening

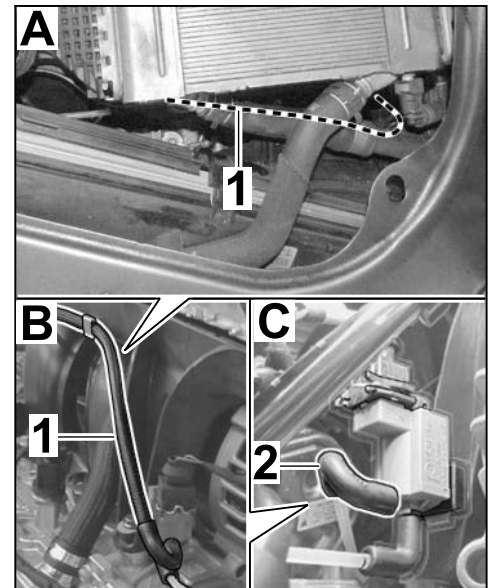

Figure 31

- 3.7.4 Route vacuum line at the right side along the charge-air cooler holder.

Clip in cable attachment (811.971.848.B) ⇒ *Figure 32-1-* on the charge-air cooler holder and fit vacuum line.

Secure vacuum line using combination holder (4.3 - 11) ⇒ *Figure 32-2-* to the vent line ⇒ *Figure 32-6-*.

Secure vacuum line using combination holder (4.3 - 25) ⇒ *Figure 32-3-* to the coolant hose ⇒ *Figure 32-4-*.

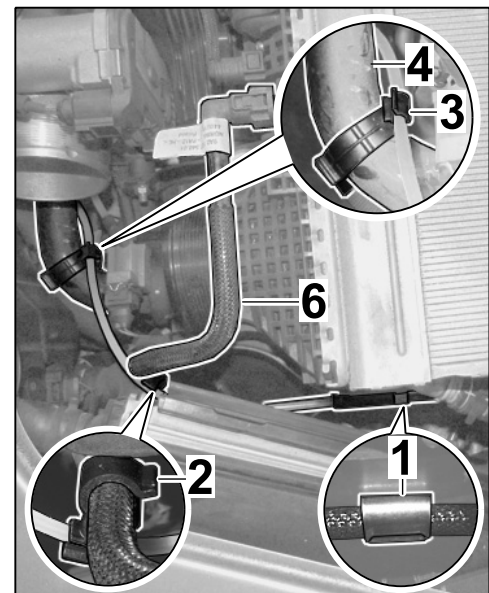

Figure 32



Information

Because the view of the components is obstructed in the installation area, they are shown with the engine removed.

- 3.7.5 **Only** for vehicles with PDK:
Route vacuum line over the transmission to the rear muffler holder at the right.

Secure vacuum line ⇒ *Figure 33-1-* to the transmission using two clamps (6.00-9.00, 3D0.971.939.B) ⇒ *Figure 33-2-*.

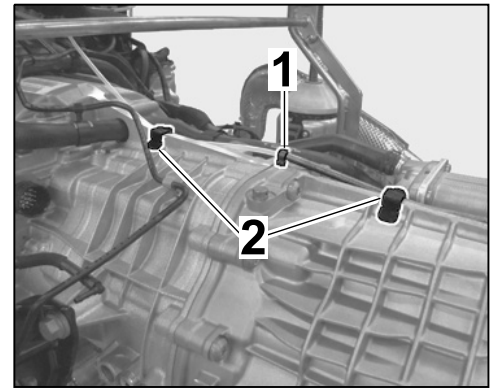

Figure 33



Information

Because the view of the components is obstructed in the installation area, they are shown with the engine removed.

- 3.7.6 **Only** for vehicles with manual transmission:
Route vacuum line over the transmission to the rear muffler holder at the right.

Secure vacuum line using combination holder (4.3 - 25) ⇒ *Figure 34-2-* to the coolant hose ⇒ *Figure 34-3-*.

Secure vacuum line ⇒ *Figure 34-1-* to the transmission using a clamp (6.00-9.00, 3D0.971.939.B).

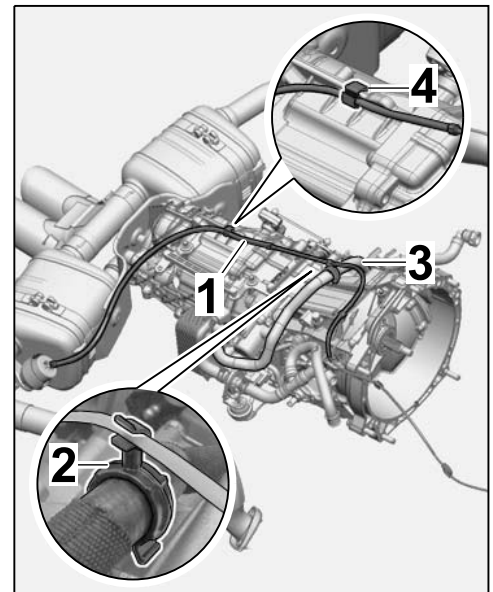

Figure 34

- 4 Install exhaust system.
 - 4.1 Install new rear mufflers. ⇒ *Workshop Manual '263319 Removing and installing rear silencer'*
 - 4.2 Adjust tailpipe cover. ⇒ *Workshop Manual '263519 Removing and installing tailpipe cover'*

- 4.3 Fit vacuum line (steel flexi-pipe) on control box.
Press single-lug clip ⇒ *Figure 35-1-* together.
Secure vacuum line (steel flexi-pipe) to the rear muffler holder using a cable attachment (6.00, 999.651.360.01) ⇒ *Figure 35-2-*.

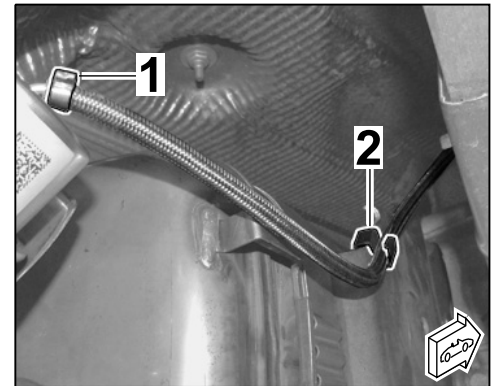

Figure 35

5 Concluding work:

- 5.1 Install molded hose ⇒ *Figure 36-1-* for the throttle housing and tighten screw-type clamps ⇒ *Figure 36-2-*.
- 5.2 Install engine compartment lid. ⇒ *Workshop Manual '557819 Removing and installing engine compartment lid'*
- 5.3 Install trim panel for rear luggage compartment (front section) ⇒ *Figure 5-6-*. ⇒ *Workshop Manual '700619 Removing and installing trim panel for rear luggage compartment (front section)'*
- 5.4 Insert storage box ⇒ *Figure 37-1-* and sound absorber ⇒ *Figure 37-2-*.
- 5.5 Install package box. ⇒ *Workshop Manual '706619 Removing and installing package box'*
- 5.6 Install C-pillar trim panel (front section) at the left. ⇒ *Workshop Manual '706819 Removing and installing C-pillar trim panel'*
- 5.7 Install trim panel for package box (lid). ⇒ *Workshop Manual '706619 Removing and installing package box'*
- 5.8 Install trim panel for convertible top compartment/engine compartment lid. ⇒ *Workshop Manual '700819 Removing and installing trim panel for convertible top compartment/engine compartment lid'*
- 5.9 Install rear cover. ⇒ *Workshop Manual '705319 Removing and installing rear cover'*

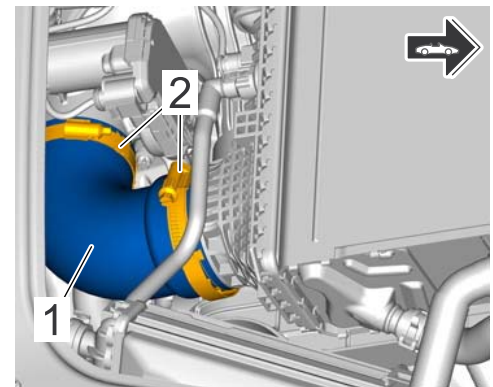

Figure 36

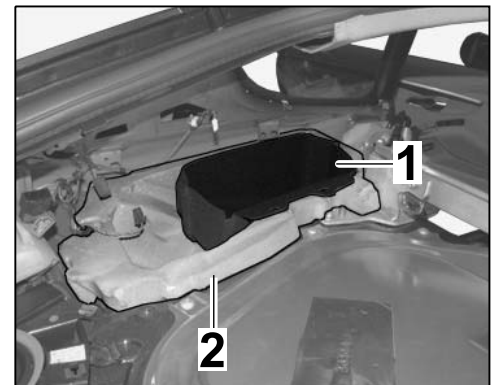

Figure 37

- 5.10 Install C-pillar trim panels (rear section) at the left and right. ⇒ *Workshop Manual '706819 Removing and installing C-pillar trim panel'*
- 5.11 Remove side trim panels for luggage compartment at the left and right. ⇒ *Workshop Manual '700319 Removing and installing side trim panel for rear luggage compartment'*
- 5.12 Install rear wall cover. ⇒ *Workshop Manual '555919 Removing and installing rear wall cover'*
- 5.13 Install trim panel for rear-wall sound absorber. ⇒ *Workshop Manual '703119 Removing and installing trim panel for rear wall'*
- 5.14 Install belt strap guide at the right and side trim panel at the left. ⇒ *Workshop Manual '707519 Removing and installing side trim panel'*
- 5.15 Secure belt fitting in the B-pillar sill area. ⇒ *Workshop Manual '691119 Removing and installing front three-point belt'*

**WARNING****Incorrect handling of safety bolts**

- **Danger of injury**
 - **Loss of torque**
- ⇒ **Always use new fastening screws and nuts following removal.**
- ⇒ **Observe specified tightening torques.**
- ⇒ **Carry out a visual inspection of all re-used parts.**

- 5.16 Install left front seat. ⇒ *Workshop Manual '720119 Removing and installing front seat'*
- 5.17 Install inner door sill trim at the left. ⇒ *Workshop Manual '680519 Removing and installing inner door sill trim'*
- 5.18 Fit rear wheels. ⇒ *Workshop Manual '440519 Removing and installing wheel'*
- 5.19 Convert switch console.
 - 5.19.1 Remove switch console. ⇒ *Workshop Manual '962719 Removing and installing switch console'*

**Information**

The switch console consists of a total of 16 buttons, 10 light guides and 10 trims. Each half can be used for the left or right row of the main body.

- 5.19.2 Assemble new switch console in accordance with the new vehicle equipment.

Fit light guide at the correct side ⇒
Figure 38-1- in the main body.

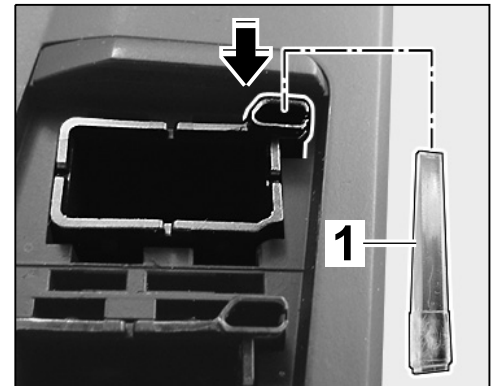

Figure 38

Fit trim ⇒ *Figure 39-1-* underneath
the button in the main body.

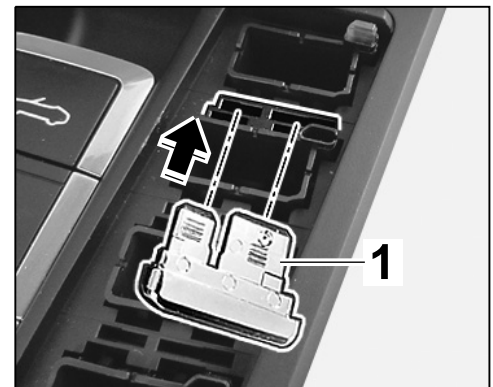

Figure 39

Position button ⇒ *Figure 40-1-* and
clip it into the main body.

- 5.19.3 Install switch console. ⇒ *Workshop
Manual '962719 Removing and
installing switch console'*

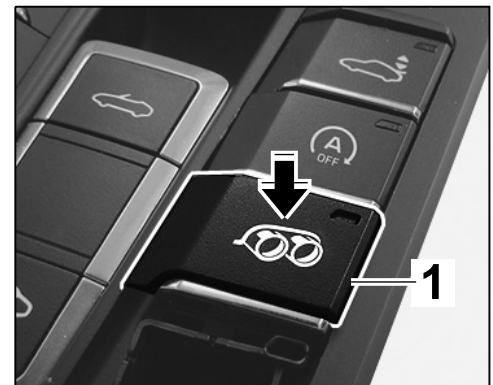

Figure 40

NOTICE

Voltage drop

- Risk of irreparable damage to control unit
- Risk of damage to control unit

- **Fault entries in the control unit**
 - **Coding in the control unit is aborted**
 - **Malfunctions in control unit, even during programming**
- ⇒ **Switch off the ignition and remove the ignition key before disconnecting the control unit.**
- ⇒ **Ensure that the power supply is not interrupted during programming.**
- ⇒ **Connect a battery charger with a current rating of at least Nominal value 70 A to the vehicle battery.**



Information

The **9900 - PIWIS Tester III** instructions take precedence since the description may be different with later Tester releases.

The procedure described here has been structured in general terms; different text or additions may appear on the **9900 - PIWIS Tester III**.

6 Code sport exhaust system.

6.1 Connect a battery charger. ⇒ *Workshop Manual '2X00IN Battery trickle charging'*

6.2 **9900 - PIWIS Tester 3** must be connected before switching on the ignition.

6.3 Select the required vehicle type. PIWIS Tester Diagnostics starts.



Information

The sport exhaust system button can only be coded on the right-hand side of the switch console.



Information

The new coding for the switch console only takes effect when the ignition is switched off, the remote control is removed and the ignition is switched back on again.

6.4 Code keypad assignment. ⇒ *Workshop Manual '962755 Replacing switch console'*

6.5 Maintenance of vehicle data

6.5.1 **Additional menu** must now be selected by pressing **•F7** .

6.5.2 Select the **Maintenance of vehicle data** function. Press **•F12** until **X numbers** appears in the Value group column.

6.5.3 Select **XLX - Sport exhaust system, silver tailpipe** or **XLX - Sport exhaust system, black tailpipe** in the Coding value column. When you touch the Installed cell, a tick appears.

6.5.4 Save the values by pressing **•F8** . Wait until the message **Modified values have been buffered** appears.

- 6.5.5 Press •F12" until •F8" can be activated.
- 6.5.6 Press •F8" to write values. Wait until the message **Generation of vehicle data is complete** appears.
- 6.5.7 Press •F12" to switch to Report management. Press •F10" to open the log and check that the vehicle equipment **XLF - Sport exhaust system, silver tailpipe** or **XLX - Sport exhaust system, black tailpipe** is displayed.
- 6.6 Adapt coding.
- 6.6.1 Press •F11" to return to the list of control units.
Select all control units.
- 6.6.2 Switch to the **Coding/adaptations** menu.
Select **Automatic coding** mode. Press •F12" to continue.
Wait until the message **Coding has been completed successfully** appears.
Press •F12" to continue.
- 6.7 Read out the fault memories of all systems, work through any existing faults and erase the fault memories. ⇒ *Workshop Manual '033500 Fault memory for on-board diagnosis'*
- 6.8 Carry out "Sport exhaust system" function test.

Start the vehicle. The exhaust flaps open when you press the "Twin tailpipe" button. The noise of the exhaust motor can be heard.
- 6.9 Disconnect the battery charger. ⇒ *Workshop Manual '2X00IN Battery trickle charging'*

26013100: Sport exhaust system installed

Labor time: **477 TU**

Includes: Removing exhaust system, installing rear muffler, removing and installing strip for switches, coding sport exhaust system.

Important Notice: Technical Bulletins issued by Porsche Cars North America, Inc. are intended only for use by professional automotive technicians who have attended Porsche service training courses. They are written to inform those technicians of conditions that may occur on some Porsche vehicles, or to provide information that could assist in the proper servicing of a vehicle. Porsche special tools may be necessary in order to perform certain operations identified in these bulletins. Use of tools and procedures other than those Porsche recommends in these bulletins may be detrimental to the safe operation of your vehicle, and may endanger the people working on it. Properly trained Porsche technicians have the equipment, tools, safety instructions, and know-how to do the job properly and safely. If a particular condition is described, do not assume that the bulletin applies to your vehicle, or that your vehicle will have that condition. See your authorized Porsche Dealer for the latest information about whether a particular technical bulletin applies to your vehicle. Part numbers listed in these bulletins are for reference only. Always check with your authorized Porsche dealer to verify the current and correct part numbers. The work procedures updated electronically in the Porsche PIWIS diagnostic and testing device take precedence and, in the event of a discrepancy, the work procedures in the PIWIS Tester are the ones that must be followed.

© Porsche Cars North America, Inc.

Dealership	Service Manager	Shop Foreman	Service Technician
Distribution	Asst. Manager	Warranty Admin.	Service Technician
Routing			

Dr. Ing. h.c. F. Porsche AG is the owner of numerous trademarks, both registered and unregistered, including without limitation the Porsche Crest®, Porsche®, Boxster®, Carrera®, Cayenne®, Cayman®, Macan®, Panamera®, Speedster®, Spyder®, 918 Spyder®, Tiptronic®, VarioCam®, PCM®, PDK®, 911®, RS®, 4S®, FOUR, UNCOMPROMISED®, and the model numbers and the distinctive shapes of the Porsche automobiles such as, the federally registered 911 and Boxster automobiles. The third party trademarks contained herein are the properties of their respective owners. Porsche Cars North America, Inc. believes the specifications to be correct at the time of printing. Specifications, performance standards, standard equipment, options, and other elements shown are subject to change without notice. Some options may be unavailable when a car is built. Some vehicles may be shown with non-U.S. equipment. The information contained herein is for internal authorized Porsche dealer use only and cannot be copied or distributed. Porsche recommends seat belt usage and observance of traffic laws at all times.

Printed in the USA